

SIDE VIEW

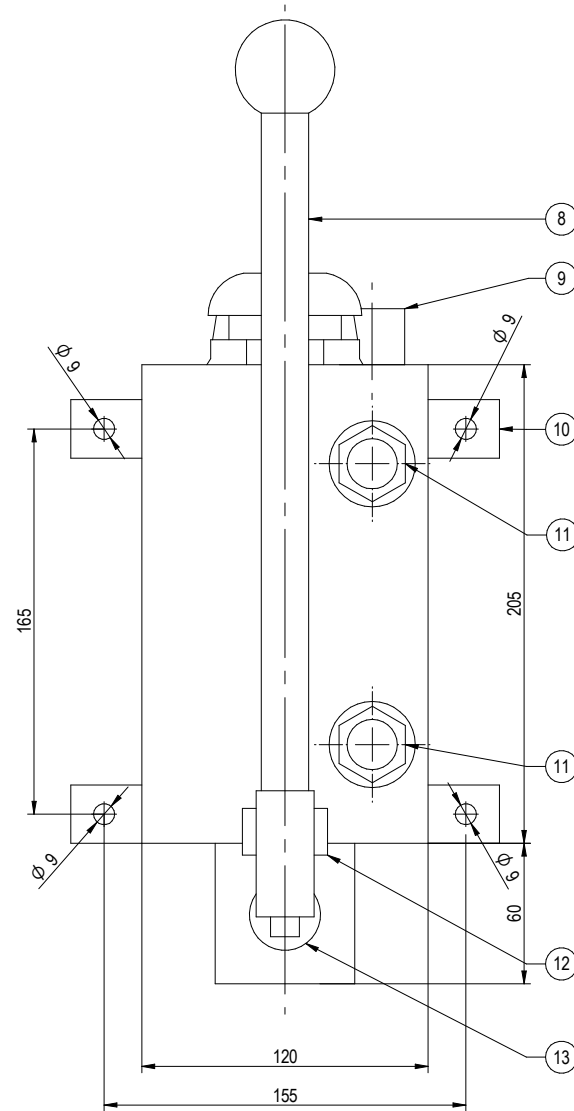

FRONT VIEW

NO	DESCRIPTION	MATERIAL	QTY	SPARE
13	PISTON	SS 316	1	
12	HANDLE MOUNTING SEAT	SS 304	1	
11	LEVEL GAUGE	SS 316	2	
10	MOUNTING BRACKET	SS 304	4	
9	INLET OIL INJECTION, 1/2" NPT	SS 316	1	
8	HANDLE	SS 304	1	
7	PUMP BODY	SS 304	1	
6	OUTLET CHECK VALVE, 1/2" NPT	SS 316	1	
5	LOWER COVER	SS 304	1	
4	NAME PLATE	STAINLESS STEEL	1	
3	OIL COVER	SS 304	1	
2	TOP COVER	SS 304	1	
1	CAP INLET OIL	PLASTIC BLACK	1	

TOLERANCE (MM)		
OVER	TO	VALUE
0	500	±2
500	1000	±5
1000	-	±10
ANGULAR		±2°

MATERIAL :
SEE LIST

QTY :

CUSTOMER DATA:

NTS	SH	ND	RW	23-09-2021	DATE	DESCRIPTION	E
SCALE	BY	CHKD	APPD	DATE	DESCRIPTION	REV	
TITLE : HAND PUMP TYPE HP-2							DESIGN FSDI
FILE REFERENCE :							mm
DWG NO: F-HP001-2L						SHT NO:	ISSUE
1 OF 1							E